

Pyrometry, Laboratory Ceramics & Furnace Construction

Engineering Ceramic

Highest product reliability.

Manufactured according to the highest quality criteria.

Individual customized solutions for design, configuration and manufacturing precision.

Short lead times.

Comprehensive service.



Manufactured for highest requirements. For service as well.

Engineering ceramics has a name: Schunk. Whether it is the production of standardized ceramics or ceramics developed individually for your needs with manufacturing tolerances far below the usual standards – Schunk always offers an outstanding product. With technical ceramics that are based on industrial standards, come from German production and are produced in compliance with the strictest quality standards. In addition to the functional design, Schunk also fea-

tures maximum flexibility in the implementation of customer requirements and short lead times of the products. Our local contacts provide you with comprehensive service. They give advice for the many possible applications and are available to answer questions regarding customized applications.

Engineering Ceramic

ADVANTAGES

Exceptional accuracy to size.

High chemical and temperature resistance.

Outstanding operational safety and efficiency.

German manufacturing according to the strictest quality standards (VDE 0335, ISO 9001).





Continuously resistant - even in continuous operation.

Our laboratory ceramic products are characterized by high purity and chemical resistance – for example, against aggressive gases and fluxes.



Maintains its shape - at any temperature.

Ceramic components offer within kiln and plant engineering, for example, in high temperature ranges the best dimensional stability and very good oxidation and corrosion resistance.



Highly resilient - even under pressure

The engineered ceramics made by Schunk are mechanically highly resilient, even under very demanding operational conditions like mechanical engineering.



Technical data

		10A	H	HE	TEH		
	Unit	AluSIK-60 ZA	AluSIK-80 GA AluSIK-80 ZA	AluSIK-60 ZB	AluSIK-99 GB AluSIK-99 ZA	CarSIK-70 ZA	CarSIK-90 ZA
Type acc. DIN VDE 0335		C 610	C 530	–	C 799	–	–
Pages		6-8, 14-17	12, 14-15	13	9-11, 14-24	13	13
		Mullite	Corundum	Sillimanite	Aluminium oxide	Mullite-bonded SiC	Mullite-bonded SiC
Al₂O₃ content	%	60	80	60	99.7	70 SiC*	90 SiC*
Type of body		Impervious	Porous	Porous	Impervious	Porous	Porous
Bulk density	g/cm ³	2.7	2.4	2.3	3.8	2.1	2.2
Flexural strength 20 °C (3-point)	MPa	120	30	30	300	30	30
Open Porosity	%	0	27	22	0	25	25
Limit of application	°C	1600	1500	1400	1750	1400	1450
Thermal expansion 20–1000 °C	10 ⁻⁶ K ⁻¹	5.5	5.8	6.5	8	5	5
Thermal conductivity 20–100 °C	W/mK	5	2	1.5	25	7	25
Thermal shock resistance		Good	Excellent	Good	Medium to good	Excellent	Excellent
Spec. electric resistance at RT	Ω cm	10 ¹³	–	–	10 ¹⁴	–	–
600 °C		10 ⁶	10 ⁶	10 ⁶	10 ⁸	–	–
Max. Manufacturing length for tubes	mm	3000	3000	3000	3000	2200	1900

*Addition of SiC to mix

Qualities	Unit	ZirSIK-95 TA
Chemical analysis		ZrO ₂ 95 % CaO 4 %
Bulk density	g/cm ³	4.3
Open Porosity	%	25
Limit of application · oxidizing · reducing · vacuum	°C	2400 2100 2200
Thermal conductivity 20–100 °C	W/mK	2
Thermal expansion 20–1000 °C	10 ⁻⁶ K ⁻¹	9.6

These property values were determined with test pieces and are used to determine the characteristics of our products according to the best of our knowledge.

The realization of these values is strongly influenced by the geometry of the product and the operational conditions.

The standard products in the catalog are identified by order numbers and are listed with the dimensions. The tubes are listed with OD and ID.

We use the following abbreviations in our order documentation:

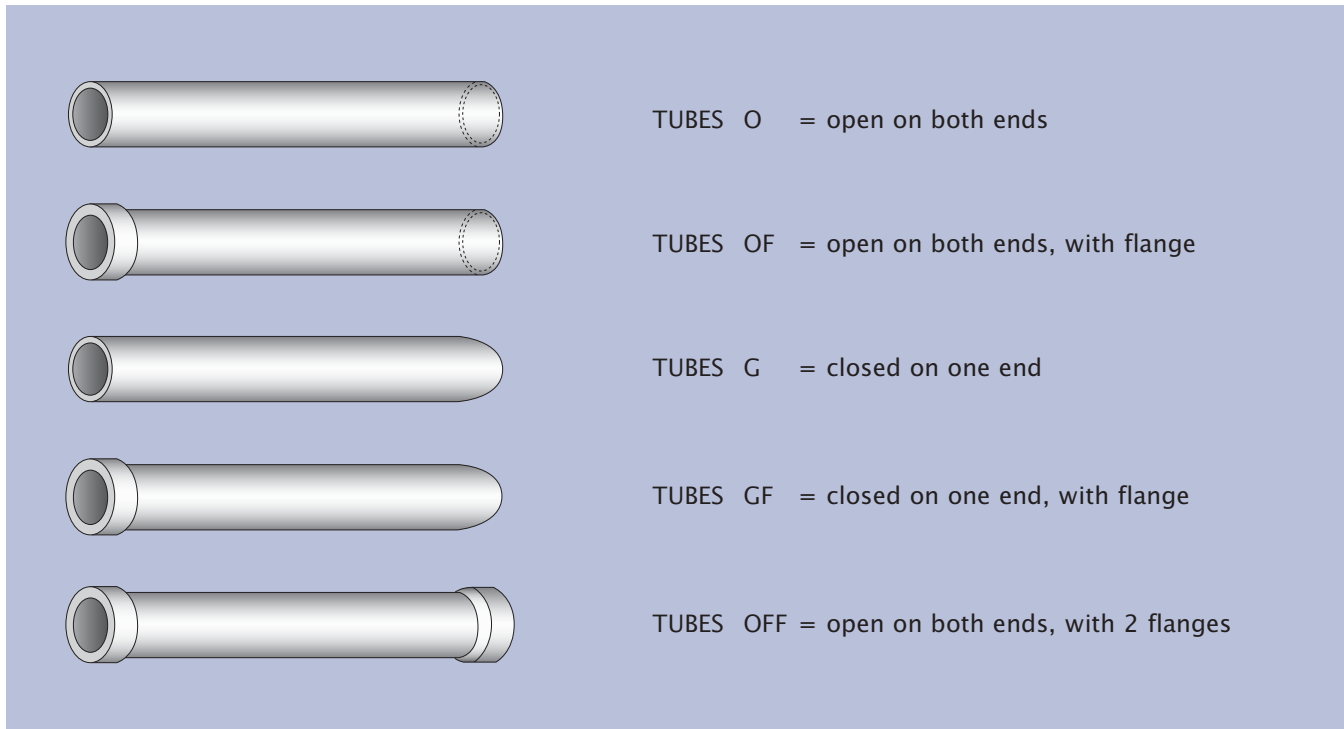

The desired lengths for tubes not standardized by a DIN standard are specified behind the letter "L" in millimeters.

Flange dimensions are indicated in parenthesis as follows:

Flange diameter x height in mm, for example (F 40 x 5)

Insulating tubes:

A = 5, B = 10, C = 25, D = 50, E = 75 and F = 100 mm.

Insulating tubes with slot:

Please add an "S" behind the length specification, i. e.

for 2 bores 1 slot

for 4 bores 2 slots.

Mullite tubes

10A

H

HE

TEH

AluSIK-60 ZA

10A Type C 610



OD in mm	ID in mm	OD in mm	ID in mm
1.5	0.8	28	20
2	1	28	23
3	1.5	30	23
3	2	30	25
4	2	32	26
5	3	33	28
6	4	36	30
7	4	38	30
8	5	40	32
9	6	43	37
10	7	46	40
11	7	48	40
12	8	50	40
14	10	50	42
15	11	54	46
16	12	60	50
17	13	66	56
18	14	70	60
19	13	75	65
19	15	80	70
20	15	90	76
22	18	95	80
22	15	105	90
24	19	115	100
26	20		

Please ask us about larger and/or different dimension.

AluSIK-60 ZA

10A Type C 610

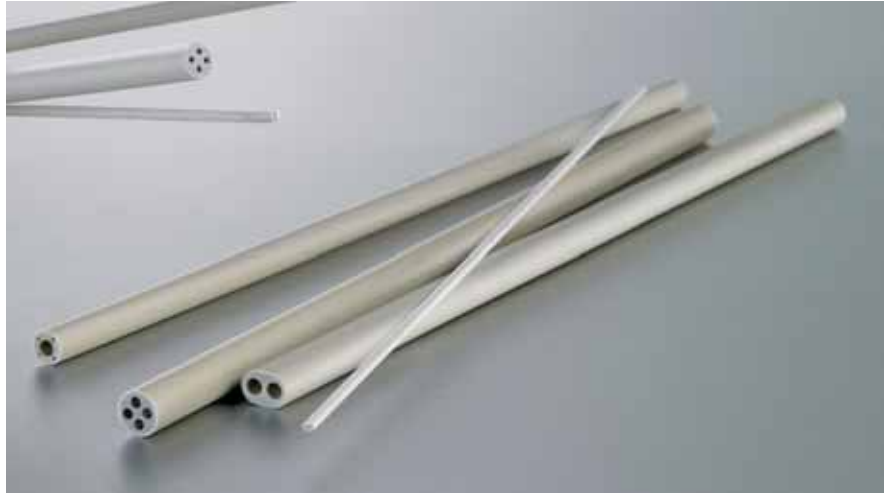

2-bore-rods

OD in mm	ID in mm
2.2	0.5
3	0.8
3/2 Oval	0.8
4	1
4.5	1.5
5/3 Oval	1.6
6	1.8
7.5/4.5 Oval	2.3
8	2
8.5	2.5
10	2.7
12	3
15.5	4.5
12/8 Oval	4

4-bore-rods

OD in mm	ID in mm
4	1
4.5	1
5.5	1.2
8.5	1.5
9	2.5
11	2.5

5-bore-rods with centre bore and 4 bores

OD in mm	Centre bore Ø in mm	Bore Ø in mm
8.5	4	1.1
13.8	6	1.5

Please ask us about larger and/or different dimension.

Insulating tubes for thermocouples

10A

H

HE

TEH

AluSIK-60 ZA

10A Type C 610



OD in mm	ID in mm
1*	0.5
1.5*	0.8
2*	1
2.7	1.7
3	1.2
3.5	2.5
4	2
5	3
6	4
7	4.5

*Only for lengths of 25 and 50 mm.

For lengths: A = 5 mm, B = 10 mm,
C = 25 mm, D = 50 mm, E = 75 mm,
F = 100 mm with **one** bore.

Bores	OD in mm	ID in mm
2	2.2*	0.5
2	3*	0.8
2	4	1
4	4.5	1
4	5.5	1.2
2	6	1.8
2	8*	2
2	8.5*	2.5
4	8.5*	1.5
2	10*	2.7
2	12/8* Oval	4
2	3/2 Oval	0.8
2	5/3 Oval	1.6
2	7.5/4.5 Oval	2.3
4	9*	2.5

*Only for lengths of 25 and 50 mm.

For lengths: A = 5 mm, B = 10 mm, C = 25 mm, D = 50 mm, E = 75 mm,
F = 100 mm with **two and four** bores.

AluSIK-99 ZA

TEH Type C 799



OD in mm	ID in mm	OD in mm	ID in mm
1	0.5	17	12
1.5	0.8	20	15
2	1	22	17
3	1.5	24	18
4	2	27	17
5	3	27	20
6	3	30	21
6	4	30	23
7	4	32	25
7	5	35	27
8	5	38	30
9	6	40	30
10	6	42	34
10	7	46	38
11	7	50	40
12	6	58	48
12	8	60	50
12	9	65	55
14	10	70	60
15	10	75	65
15	11	80	68
16	12		

Insulating rods for thermocouples

10A

H

HE

TEH

AluSIK-99 ZA

TEH Type C 799



2-bore-rods

OD in mm	ID in mm
2.2	0.5
3	0.8
3/2 Oval	0.8
4	1
5	1.5
5.5	1.5
6	1.8
8	2
8.5	2.5
10	2.7
12	3
15.5	4.5
12/8 Oval	4

4-bore-rods

OD in mm	ID in mm
2.5	0.6
3.5	0.7
4	1
4.5	1
5	1
5.5	1.2
6	1.8
8	2
8.5	1.5
11	2.5

6-bore-rods

OD in mm	ID in mm
4.5	0.8
4.5	1
5	0.8
5.5	1
7	1
8.5	1

5-bore-rods with centre bore and 4 bores

OD in mm	Centre bore Ø in mm	Bore Ø in mm
8.5	4	0.8
8.5	4	1.1
8.5	4	1.3

Insulating tubes for thermocouples

AluSIK-99 ZA

TEH Type C 799



OD in mm	ID in mm
1*	0.5*
1.5*	0.8*
2*	1*
2.7	1.7
3	1.2
4	2
5	3
6	4
7	4.5

**Only for lengths of 25 und 50 mm*

For lengths: A = 5 mm, B = 10 mm,
C = 25 mm, D = 50 mm, E = 75 mm,
F = 100 mm with **one** bore.

Bores	OD in mm	ID in mm
2	3/2* Oval	0.8
2	3*	0.8
2	4	1
4	4.5	1
4	5.5	1.2
2	6	1.8
2	8*	2
2	8.5*	2.5
4	8.5*	1.5
2	12/8* Oval	4

**Only for lengths of 25 und 50 mm*

For lengths: A = 5 mm, B = 10 mm, C = 25 mm, D = 50 mm, E = 75 mm,
F = 100 mm with **two and four** bores.

Corundum tubes, Corundum threaded tubes

10A

H

HE

TEH

AluSIK-80 ZA

H Type C 530



OD in mm	ID in mm	OD in mm	ID in mm
16	10	75	65
20	12	80	70
22	15	85	75
23	17	95	80
26	18	100	85
30	20	110	90
30	22	120	100
35	26	130	110
35	28	140	120
40	30	150	130
40	32	160	140
50	40	170	150
60	50	180	160
65	55	190	170
70	60	200	180

OD in mm	Thread pitch
15	2.0 mm
20	2.0 mm
25	2.0 mm
30	2.0 mm
35	2.5 mm
40	2.5 mm
45	2.5 mm
50	2.5 mm
60	3.0 mm
75	3.0 mm
80	3.5 mm
90	3.5 mm

Maximum manufacturing length 1000 mm, wall thickness (depending on OD) 5-15 mm, however, due to production reasons, wall thickness is not uniform along the entire length.

Sillimanite supporting tubes, Silicon carbide tubes

AluSIK-60 ZB

HE



CarSIK-70 ZA

CarSIK-90 ZA

OD in mm	ID in mm
15	7
18	12
20	12
22	16
23	13
25	12
25	15
25	18
30	20
35	25
40	30
45	35
50	40
55	45
60	48

OD in mm	ID in mm
16	10
20	12
23	17
26	18
30	22
35	28
40	32
45	35
50	40
60	50
65	55
70	60
75	65
80	70
95	80
120	100

OD in mm	ID in mm
15	9
23	15
26	18
30	22
35	26
40	30
45	35
50	40
55	45
60	48
70	56
75	60
80	66
95	80

Maximum length 1900 mm

Tolerances for pyrometer protection tubes

10A

H

HE

TEH

DIN 43724

Issue 1979

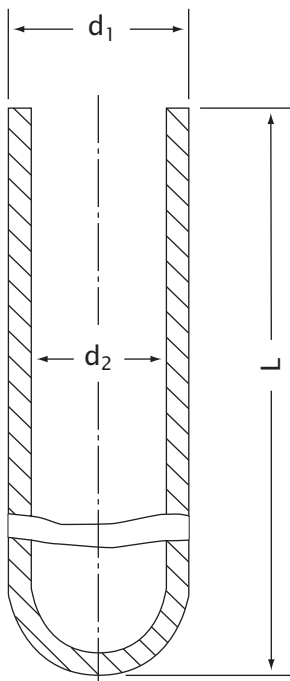

VDE 0335 Type	OD d_1 (mm)	ID d_2 (mm)	Length in mm $L \pm 2$
	10	7	
C 610	15	11	
	24	19	
	10	6	270, 375, 530, 740, 1030, 1430, 2030
C 799	15	10	
	24	18	
C 530	26	18	

Over the length of 20 mm, d_1 has to be maintained with a tolerance of ± 0.5 mm.

For d_2 : Acceptable deviation of the wall thickness according to DIN 40680 Part 1, degree of accuracy coarse.

Acceptable deflection according to DIN 40680 Part 2, degree of accuracy fine with the following definition: It must be possible to insert a straight rod with a diameter of $0.8 \times (d_1 - 2s)$ all the way to the bottom of the protection tube.

Bottom of the protection tube rounded with a smooth transition to the cylindrical part of the protection tube.

Mullite, Aluminum oxide, Corundum outer protection tubes

AluSIK-60 ZA

10 A Type C 610

Length mm	OD in mm	ID in mm
270	10	7
375	10	7
530	10	7
740	10	7
1030	10	7
1430	10	7
2030	10	7
270	15	11
375	15	11
530	15	11
740	15	11
1030	15	11
1430	15	11
2030	15	11
270	24	19
375	24	19
530	24	19
740	24	19
1030	24	19
1430	24	19
2030	24	19

AluSIK-99 ZA

TEH Type C 799

Length mm	OD in mm	ID in mm
270	10	6
375	10	6
530	10	6
740	10	6
1030	10	6
1430	10	6
2030	10	6
270	15	10
375	15	10
530	15	10
740	15	10
1030	15	10
1430	15	10
2030	15	10
270	24	18
375	24	18
530	24	18
740	24	18
1030	24	18
1430	24	18
2030	24	18

AluSIK-80 ZA

H Type C 530

Length mm	OD in mm	ID in mm
270	26	18
375	26	18
530	26	18
740	26	18
1030	26	18
1430	26	18
2030	26	18

DIN-tubes are closed one end and without flange.

Tolerances for insulating tubes for thermocouples with 4 bores

DIN 43725

Issue 1990

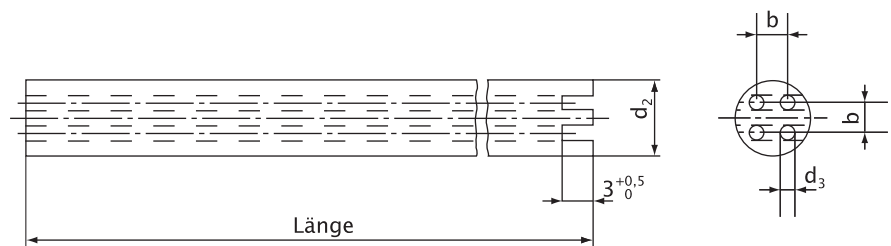

VDE 0335 Type	OD d_2 (mm) $\pm 0,3$	Distance b (mm) $\pm 0,1$	Bore $\varnothing d_3$ (mm) $\pm 0,1$	Length mm ± 2	For Wire \varnothing (mm)
	5.5 ¹⁾	2	1.2		
C 610, C 799				275, 380, 560, 770, 1060, 1460, 2060	≤ 0.8
	8.5 ¹⁾	3	1.5		

¹⁾ It must be possible to insert an insulating tube with four bores of $d_2 = 5.5$ mm into a tube with an ID of 6 mm and it must be possible to insert an insulating tube with four bores of $d_2 = 8.5$ mm into a tube with an ID of 10 mm. It must be possible to insert a wire with a diameter of 1 mm into the bores.

Mullite insulating tubes, Aluminum oxide insulating tubes

AluSIK-60 ZA

10 A
Type C 610

Length mm	Bores	OD in mm	ID in mm
275	4	5.5	1.2
380	4	5.5	1.2
560	4	5.5	1.2
770	4	5.5	1.2
1060	4	5.5	1.2
1460	4	5.5	1.2
2060	4	5.5	1.2
275	4	8.5	1.5
380	4	8.5	1.5
560	4	8.5	1.5
770	4	8.5	1.5
1060	4	8.5	1.5
1460	4	8.5	1.5
2060	4	8.5	1.5

Also available with one or two slots.

AluSIK-99 ZA

TEH
Type C 799

Length mm	Bores	OD in mm	ID in mm
275	4	5.5	1.2
380	4	5.5	1.2
560	4	5.5	1.2
770	4	5.5	1.2
1060	4	5.5	1.2
1460	4	5.5	1.2
2060	4	5.5	1.2
275	4	8.5	1.5
380	4	8.5	1.5
560	4	8.5	1.5
770	4	8.5	1.5
1060	4	8.5	1.5
1460	4	8.5	1.5
2060	4	8.5	1.5

Also available with one or two slots.

AluSIK-99 GB

Crucibles, conical shape Type C 799

Order #	Height mm	OD at the top mm	Volume ccm	Wall thickness mm
T 001	ca. 39	ca. 44	22	2
T 002	ca. 59	ca. 60	75	3
T 003	ca. 78	ca. 72	160	3
T 004	ca. 89	ca. 82	240	3
T 005	ca. 97	ca. 82	250	3.5
T 006	ca. 168	ca. 99	780	4.5
T 007	ca. 225	ca. 135	1670	4.5

Short crucibles, conical shape Type C 799

Order #	Height mm	OD at the top mm	Volume ccm	Wall thickness mm
T 110	17	20	3	2
T 111	23	30	9	2.5
T 112	30	40	24	3
T 113	40	50	45	3
T 114	50	61	80	3
T 115	56	70	120	3
T 116	62	80	180	3.5

Tall crucibles, conical shape Type C 799

Order #	Height mm	OD at the top mm	Volume ccm	Wall thickness mm
T 120	34	34	20	3
T 121	45	45	30	3
T 122	61	56	60	3



AluSIK-99 GB

Slim crucibles, conical shape Type C 799

Order #	Height mm	OD at the top mm	Volume ccm	Wall thickness mm
T 130	25	20	4	2
T 131	33	25	6	2
T 132	54	35	25	3
T 133	77	45	60	3
T 134	91	56	90	3
T 135	120	66	180	3
T 136	140	75	300	4
T 137	161	86	540	4

Crucibles

AluSIK-99 GB

Cylindrical crucibles Type C 799

Order #	Length mm	Ø mm
T 010	100	18 x 14
T 011	100	22 x 17
T 012	100	28 x 23
T 013	100	34 x 28
T 014	100	38 x 32
T 015	100	42 x 36
T 016	100	49 x 43
T 017	100	53 x 45
T 018	100	60 x 51
T 019	100	66 x 56
T 020	200	38 x 32
T 021	200	42 x 36
T 022	200	49 x 43
T 023	200	53 x 45
T 024	200	61 x 51
T 025	200	66 x 56



AluSIK-99 GB

Cylindrical crucibles with spherical bottom Type C 799

Order #	Height mm	OD at the top mm	Volume ccm	Wall thickness mm
T 140	6	6	0.5	1
T 141	13	10	1	1
T 142	63	18	9	2.5
T 143	46	23	12	2.5
T 144	113	33	50	3

AluSIK-99 GB

Cylindrical crucibles Type C 799

Order #	Height mm	OD at the top mm	Volume ccm	Wall thickness mm
T 100	10	8	0,5	1
T 101	30	20	9	2
T 102	40	30	20	2.5
T 103	60	40	60	3
T 104	75	50	90	3
T 105	100	65	150	3
T 106	100	90	460	4
T 107	110	100	750	4
T 108	130	100	1000	4



AluSIK-99 GB

Ignition dishes, rectangular, conical Type C 799



Order #	Length mm	Width mm	Height mm	Wall thickness mm	Volume ccm
S 040	88	30	18	2.5	32
S 041	112	29	18	3	36
S 042	88	47	25	3	74
S 043	113	46	22	3	81
S 044	140	45	23	3	104
S 045	84	28	38	3	60
S 046	114	59	30	3.5	147
S 047	140	56	28	3.5	159

Boats

AluSIK-99 GB

Boats, with or without eye Type C 799



Order #	Length w/o eye mm	Width mm	Height mm	Volume ccm	Wall thickness mm
S 030	55	13	9	2.6	2.5
S 031	93	13	9	4.5	2.5
S 032	110	18	12	13	2.5
S 033	110	21	15	21	2.5
S 034	110	28	22	47	2.5
S 035	110	33	28	70	3
S 036	110	39	33	103	3

AluSIK-99 GB

Boats Type C 799

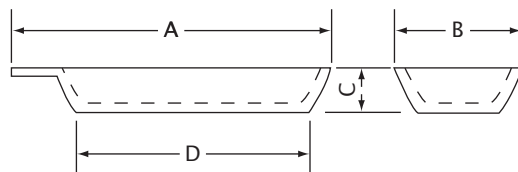

Order #	Dimensions mm				Volume ccm	Wall thickness mm
	A	B	C	D		
S 100	53	8	8	38	0.5	2.5
S 101	80	15	10	60	4	2.5
S 102	86	15	10	73	5	2.5
S 103	100	20	17	70	11	3.5
S 104	111	13	10	95	5	3.5
S 105	162	20	15	143	20	3.5
S 106	200	20	14	175	23	3.5

AluSIK-99 GB

Rectangular Dishes Type C 799

Order #	Dimensions mm				Volume ccm
	A	B	C	D	
S 120	22	12	11	2.5	1
S 121	43	29	11	2.5	7.7
S 122	53	48	15	2.5	25
S 123	85	44	16	3	39

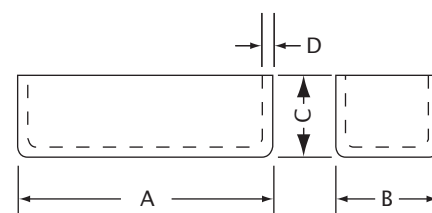

AluSIK-99 GB

Ignition Basins, round Type C 799

Order #	Dimensions mm			Volume ccm
	A	B	C	
S 110	12	8	2	0.3
S 111	25	11	2	3
S 112	41	16	2.5	13.7
S 113	66	16	3	36.7

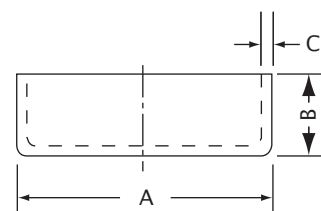

Lids, Adhesives and Mastics

AluSIK-99 GB

Lids Type C 799



Order #	ø mm	Height mm	Order #	ø mm	Height mm
T 150	8	2.5	T 159	60	5.5
T 151	20	3.5	T 160	65	5
T 152	25	3.5	T 161	73	5
T 153	29	4	T 162	78	5
T 154	35	2.6	T 163	81	4.5
T 155	40	5	T 164	84	5
T 156	45	5	T 165	92	5.5
T 157	50	4.5	T 166	100	6
T 158	55	4.5			

Adhesives and Mastics

Quality	Type	Limit of application
AluSIK-60 FA	Sillimanite	1600 °C ready-to-use mastic on sodium silicate basis
AluSIK-80 FB	Corundum	1800 °C ready-to-use mastic on sodium silicate basis

All mastic must be stored above freezing temperatures.
Ready-to-use mastic need to be used up after opening.
Ready-to-use mastic can be stored for up to 3 months at the most;
clean tap water can be added, if necessary.

Isostatically pressed crucibles

Order #	Dimensions mm				Volume ccm
	Ø A	Ø B	H ₁	H ₂	
ISO 1	93	79	185	197	900
ISO 2	86	75	209	218	920
ISO 3	116	98	195	210	1450
*ISO 3 F	115	93	184	195	1240
ISO 4	60	50	120	128	230
ISO 5	65	53	190	200	410
ISO 6	147	124	237	250	2850
*ISO 6 F	147	124	237	250	2850
ISO 7	131	111	252	266	2420
ISO 8	42	32	115	120	90
ISO 9	88	68	130	150	470
ISO 10	85	45	130	150	200

* with flat bottom

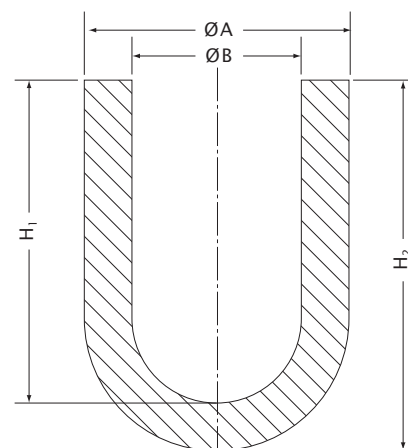

Rammed cylindrical crucibles

Order #	Dimensions mm				
	d ₁	d ₂	h ₁	h ₂	r
ZT 1	12	8	25	19	1
ZT 2	20	12	25	20	1
ZT 3	13	8	47	42	1
ZT 4	24	18	28	18	1
ZT 5	35	24	97	92	2
ZT 6	43	36	54	48	2
ZT 7	50	39	69	65	2
ZT 8	53	42	80	75	2
ZT 9	57	46	99	89	2
ZT 10	65	54	99	93	3
ZT 11	119	75	170	150	3
ZT 12	127	106	139	127	4
ZT 13	120	100	200	180	10
ZT 14	215	175	295	255	4
ZT 15	150	127	155	135	5
ZT 16	170	140	185	165	5

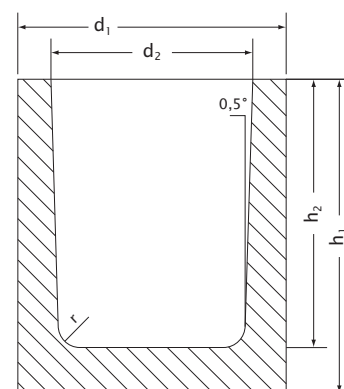

Customized products according to customer drawings available upon request.

Tolerances for diameter, length and deflection

Without grinding to DIN 40 680, issue 1983

Nominal dimensional range for diameter or length in mm		Degree of accuracy		Nominal dimensional range for lengths in mm		Degree of accuracy	
		coarse Permissible deviation in mm	medium Permissible deviation in mm			coarse Permissible deflection f_a in mm	medium Permissible deflection f_a in mm
	up to 4	± 0.4	± 0.15	up to 30	± 1.7	± 0.15	
above 4	up to 6	± 0.6	± 0.20	above 30 up to 40	± 1.8	± 0.20	
above 6	up to 8	± 0.7	± 0.25	above 40 up to 50	± 1.9	± 0.25	
above 8	up to 10	± 0.8	± 0.30	above 50 up to 60	± 2.0	± 0.30	
above 10	up to 13	± 1.0	± 0.35	above 60 up to 70	± 2.1	± 0.35	
above 13	up to 16	± 1.2	± 0.40	above 70 up to 80	± 2.1	± 0.40	
above 16	up to 20	± 1.2	± 0.45	above 80 up to 90	± 2.2	± 0.45	
above 20	up to 25	± 1.5	± 0.50	above 90 up to 100	± 2.3	± 0.50	
above 25	up to 30	± 1.5	± 0.55	above 100 up to 110	± 2.4	± 0.55	
above 30	up to 35	± 2.0	± 0.60	above 110 up to 125	± 2.5	± 0.65	
above 35	up to 40	± 2.0	± 0.65	above 125 up to 140	± 2.6	± 0.70	
above 40	up to 45	± 2.0	± 0.70	above 140 up to 155	± 2.7	± 0.80	
above 45	up to 50	± 2.5	± 0.80	above 155 up to 170	± 2.9	± 0.85	
above 50	up to 55	± 2.5	± 0.90	above 170 up to 185	± 3.0	± 0.90	
above 55	up to 60	± 2.5	± 1.00	above 185 up to 200	± 3.1	± 1.00	
above 60	up to 70	± 3.0	± 1.20	above 200 up to 250	± 3.5	± 1.25	
above 70	up to 80	± 3.5	± 1.40	above 250 up to 300	± 3.9	± 1.50	
above 80	up to 90	± 4.0	± 1.60	above 300 up to 350	± 4.3	± 1.75	
above 90	up to 100	± 4.5	± 1.80	above 350 up to 400	± 4.7	± 2.00	
above 100	up to 110	± 5.0	± 2.00	above 400 up to 450	± 5.1	± 2.25	
above 110	up to 125	± 5.5	± 2.20	above 450 up to 500	± 5.5	± 2.50	
above 125	up to 140	± 6.0	± 2.50	above 500 up to 600	± 6.3	± 3.00	
above 140	up to 155	± 6.5	± 2.80	above 600 up to 700	± 7.1	± 3.50	
above 155	up to 170	± 7.0	± 3.00	above 700 up to 800	± 7.9	± 4.00	
above 170	up to 185	± 7.5	± 3.40	above 800 up to 900	± 8.7	± 4.50	
above 185	up to 200	± 8.0	± 3.80	above 900 up to 1000	± 9.5	± 5.00	
above 200	up to 250	± 9.0	± 4.20	above 1000	± 1.5+0.8% xL	± 0.5 % xL	
above 250	up to 300	± 10.0	± 4.60				
above 300	up to 350	± 11.0	± 5.00				
above 350	up to 400	± 12.0	± 5.50				
above 400	up to 450	± 13.0	± 6.10				
above 450	up to 500	± 14.0	± 6.80				
above 500	up to 600	± 15.0	± 7.60				
above 600	up to 700	± 16.0	± 8.30				
above 700	up to 800	± 17.5	± 9.00				
above 800	up to 900	± 19.0	± 9.50				
above 900	up to 1000	± 20.0	± 10.00				
above 1000		± 0.02 x D	± 0.01 x D				
Degree of accuracy		coarse			medium		
VDE 0335, Type		530	610	799	530	610	799
Manufacturing method							
Cast and extruded for parts Ø 30 mm and above		•	•	•			
Extruded for parts up to Ø 30 mm					•	•	•

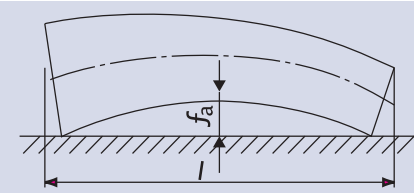
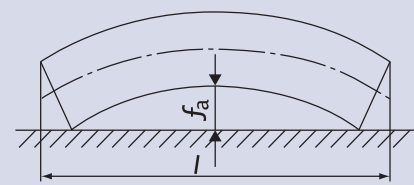

● Manufacturing method customary

Owing to a modern process control system we are able to achieve values on diameter, length and bending which are considerably better than standardized. Should you require smaller tolerances, please send us your inquiry. Those data stipulated for the "coarse" degree of accuracy do not apply for the first production, for which instead we have to come to a special agreement.

Schunk Ingenieurkeramik GmbH

Hanns-Martin-Schleyer-Straße 5
47877 Willich-Münchheide
Germany

Phone: +49 (0)21 54/49 7-0
Fax: +49 (0)21 54/49 7-111

infobox@schunk-group.com
www.schunk-sik.com